

Scheme assembly of the camera

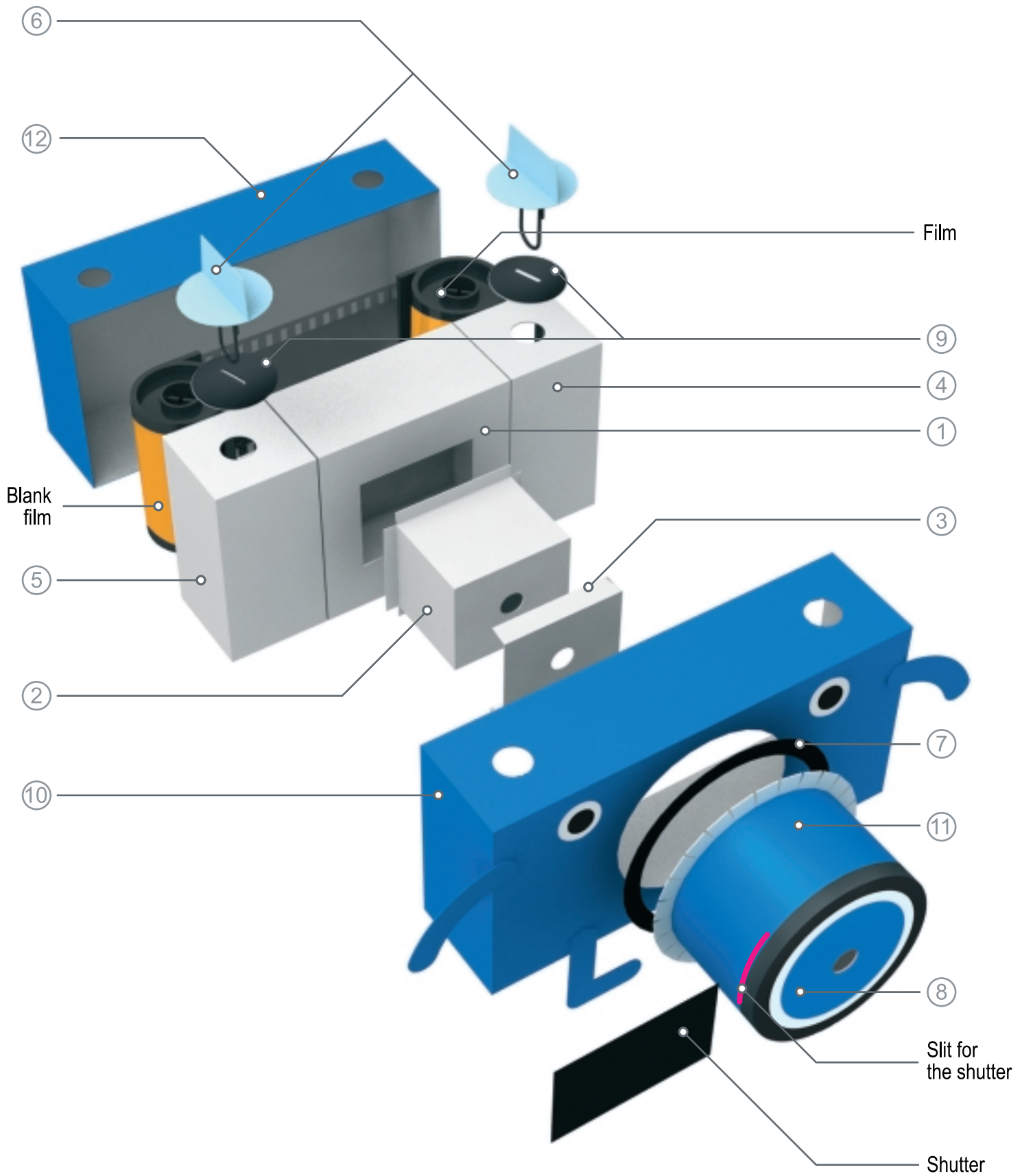

Scheme assembly of the camera

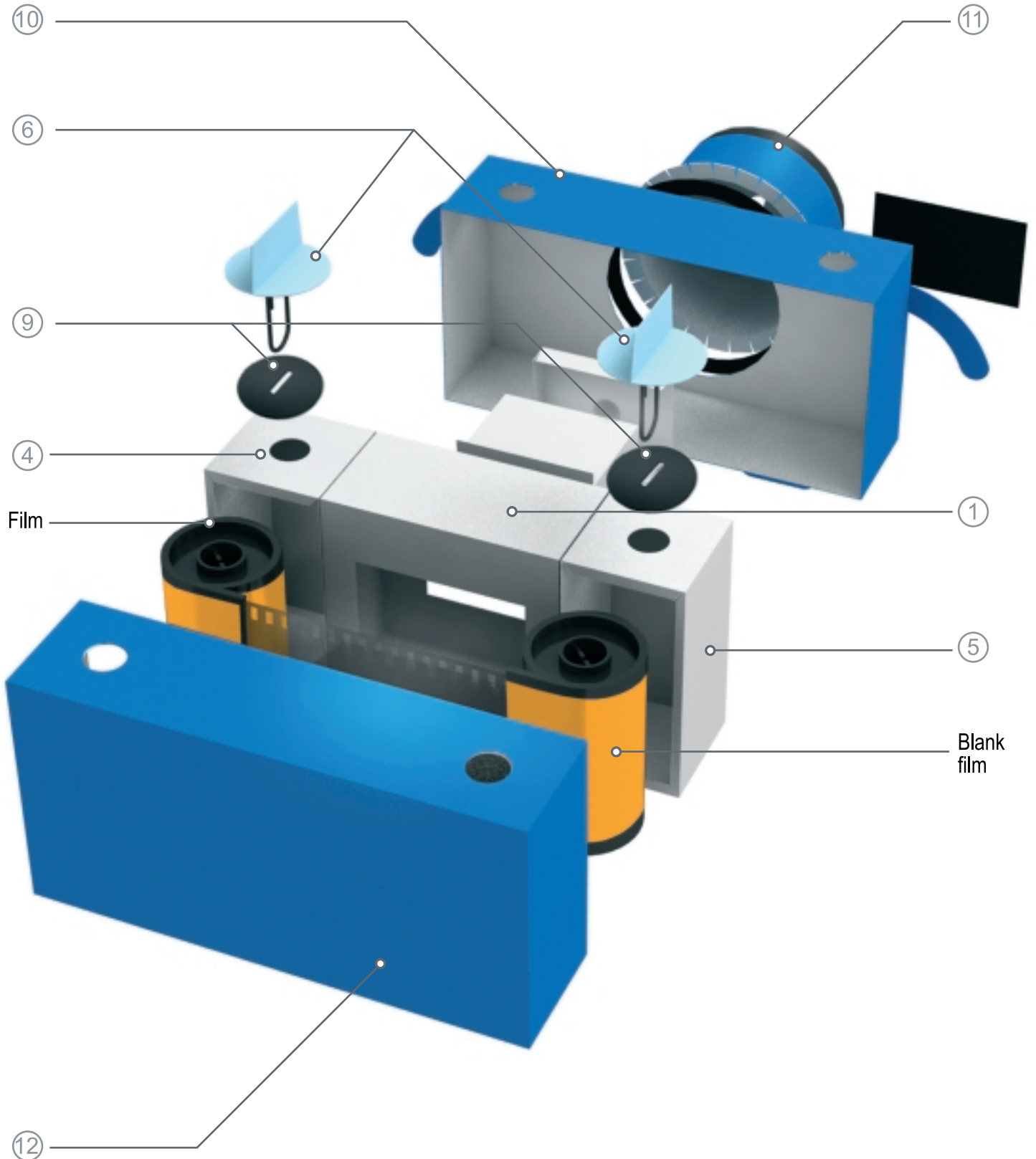

Scheme assembly of the camera



1. Print two pages and carefully cut the pattern details.



2. By the dotted lines you should do the folds.



3. Carefully glue.



4. Glue the part number 11



5. Parts 1, 2, 4 and 5 on the outside glue with foil. You should look at a bright light through the detail to make sure that it does not shine through.



6. On top of foil you should glue part number 3, which will become part of the shutter mechanism. You should glue it not very close, so the shutter can opens and closes freely. Look at the diagram on page number 5.

Scheme assembly of the camera

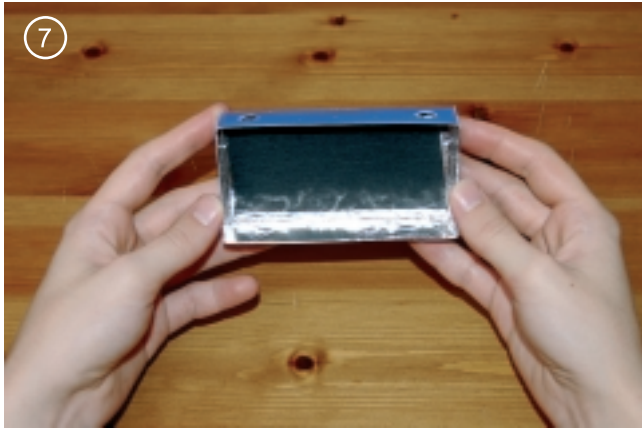

7. Attention! Item number 12 on the inside glue with foil and cover with dark piece of cardboard mat.



8. Embed clips into the details of number 6. They will be part of a mechanism to scroll through the film.



9. Disassemble an empty bobbin and insert the film.



10. Assemble the camera and insert the part number 6 so that you can turn the film. See scheme on page 5.

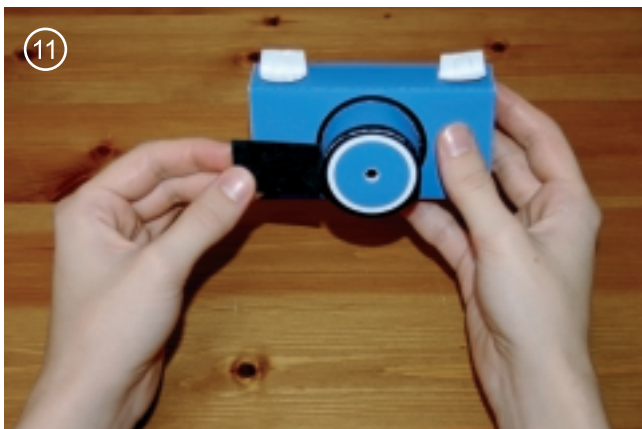

11. You should make a slit for the shutter in the outer lens, so that it could get into the shutter mechanism on the internal lens.. See scheme on page 5. Carefully pierce a needle hole in the foil with a diameter of 0.4 mm.



12. Rotating parts number 6 counter-clockwise 360 degrees, it's one shot. On a bright sunny day the shutter open for half a second. On a cloudy day the shutter open for 3 a seconds.

Scheme assembly of the camera (Top view)

